

RoHS Compliant
850 nm Multi-mode Transceiver
Small Form Pluggable (SFP), with Diagnostic Monitoring
Fiber Channel 10G,8.5G,4.25G, 2.125G, 1.0625Gb/s,
10G BASE-SW/SR,1000 Base-SX Ethernet

Recommended Operating Conditions

PARAMETER	SYMBOL	MIN	MAX	UNITS	NOTE
Case operating Temperature	T_C	-10	70	°C	
Supply Voltage	V_{CC}	3.1	3.5	V	
Supply Current	$I_{TX} + I_{RX}$	---	200	mA	

Transmitter Electro-optical Characteristics

$V_{CC} = 3.1\text{ V to }3.5\text{ V}, T_C = -10\text{ °C to }70\text{ °C}$

PARAMETER	SYMBOL	MIN	TYP.	MAX	UNITS	NOTE
Output Optical Power (50/125 μm fiber, NA=0.20) (62.5/125 μm fiber, NA=0.275)	P_{out}	-7.1	---	-1	dBm	
Optical Modulation Amplitude	OMA	-4.3			dBm	
Center Wavelength	λ_C	840	850	860	nm	
Spectral Width (RMS)	$\Delta\lambda$	---	---	0.45	nm	
Relative Intensity Noise	RIN	---	---	-128	dB/Hz	
Output Eye						Compliant with fiber channel 8x
Max. P_{out} TX-DISABLE Asserted	P_{OFF}	---	---	-35	dBm	
Differential Input Voltage	V_{DIFF}	0.35	---	2.0	V	
Transmit Fault Output-Low	TX_FAULT_L	0.0	---	0.5	V	
Transmit Fault Output-High	TX_FAULT_H	2.4	---	V_{CC}	V	
TX_DISABLE Assert Time	t_{off}	---	---	10	μs	
TX_DISABLE Negate Time	t_{on}	---	---	1	ms	
Time to initialize, include reset of TX_FAULT	t_{init}	---	---	300	ms	
TX_FAULT from fault to assertion	t_{fault}	---	---	100	μs	
TX_DISABLE time to start reset	t_{reset}	10	---	---	μs	

RoHS Compliant
850 nm Multi-mode Transceiver
Small Form Pluggable (SFP), with Diagnostic Monitoring
Fiber Channel 10G,8.5G,4.25G, 2.125G, 1.0625Gb/s,
10G BASE-SW/SR,1000 Base-SX Ethernet

Receiver Electro-optical Characteristics

$V_{CC} = 3.1\text{ V to }3.5\text{ V}, T_C = -10^\circ\text{C to }70^\circ\text{C}$

PARAMETER	SYMBOL	MIN	TYP.	MAX	UNITS	NOTE
Optical Input Power-maximum	P_{IN}	-1	---	---	dBm	BER < 10^{-12}
Receiver Sensitivity(@8.5GBps)	P_{IN}	---	---	-9.9	dBm	BER < 10^{-12}
Receiver Sensitivity(@8.5GBps)	P_{IN}	---	---	-11.1	dBm	OMA, BER < 10^{-12}
Operating Center Wavelength	λ_C	840	---	860	nm	
Optical Return Loss	ORL	12	---	---	dB	
Loss of Signal-Asserted	P_A	-12	---	---	dBm	
Loss of Signal-Deasserted	P_D	---	---	-20	dBm	
Differential Output Voltage	V_{DIFF}	0.5	---	1.2	V	
Receiver Loss of Signal Output Voltage-Low	RX_LOS_L	0	---	0.5	V	
Receiver Loss of Signal Output Voltage-High	RX_LOS_H	2.4	---	V_{CC}	V	
Receiver Loss of Signal Assert Time (off to on)	t_{A,RX_LOS}	---	---	100	μs	
Receiver Loss of Signal Assert Time (on to off)	t_{D,RX_LOS}	---	---	100	μs	

RoHS Compliant
850 nm Multi-mode Transceiver
Small Form Pluggable (SFP), with Diagnostic Monitoring
Fiber Channel 10G,8.5G,4.25G, 2.125G, 1.0625Gb/s,
10G BASE-SW/SR,1000 Base-SX Ethernet

Block Diagram of Transceiver

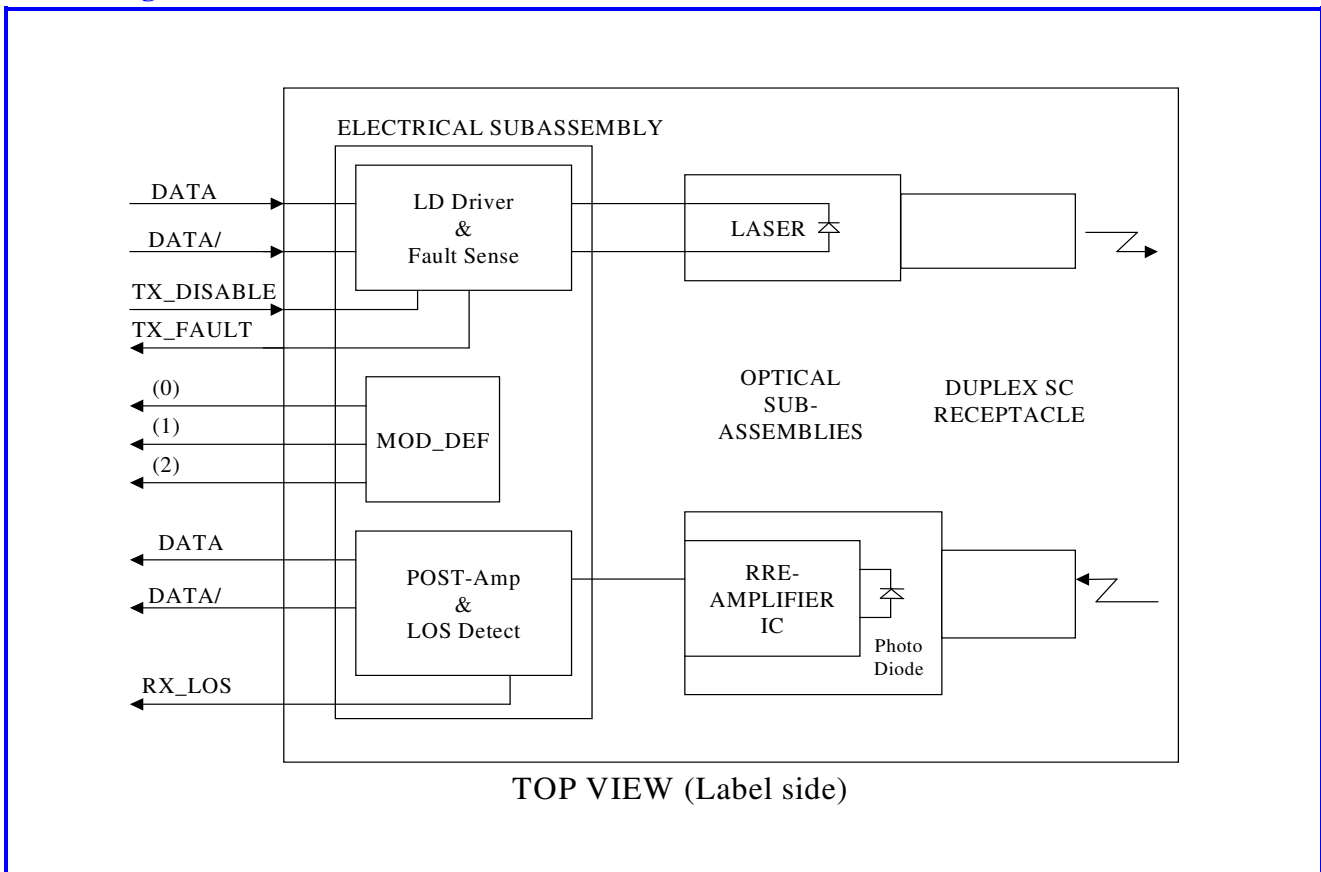

Transmitter Section

The transmitter section consists of a 850 nm VCSEL in an eye safe optical subassembly (OSA) which mates to the fiber cable. The laser OSA is driven by a LD driver IC which converts differential input LVPECL logic signals into an analog laser driving current.

TX_FAULT

When sensing an improper power level in the laser driver, the SFP set this signal high and turns off the Laser. TX_FAULT can be reset with the TX_DISABLE line. The signal is in TTL level.

TX_DISABLE

The TX_DISABLE signal is high (TTL logic "1") to turn off the laser output. The laser will turn on within 1ms when

RoHS Compliant
850 nm Multi-mode Transceiver
Small Form Pluggable (SFP), with Diagnostic Monitoring
Fiber Channel 10G,8.5G,4.25G, 2.125G, 1.0625Gb/s,
10G BASE-SW/SR,1000 Base-SX Ethernet

TX_DISABLE is low (TTL logic "0").

Receiver Section

The receiver utilizes a MSM detector integrated with a trans-impedance preamplifier in an OSA. This OSA is connected to a circuit providing post-amplification quantization, and optical signal detection.

Receive Loss (RX_LOS)

The RX_LOS is high (logic "1") when there is no incoming light from the companion transceiver. This signal is normally used by the system for the diagnostic purpose. The signal is operated in TTL level.

RoHS Compliant
850 nm Multi-mode Transceiver
Small Form Pluggable (SFP), with Diagnostic Monitoring
Fiber Channel 10G,8.5G,4.25G, 2.125G, 1.0625Gb/s,
10G BASE-SW/SR,1000 Base-SX Ethernet

Dimensions

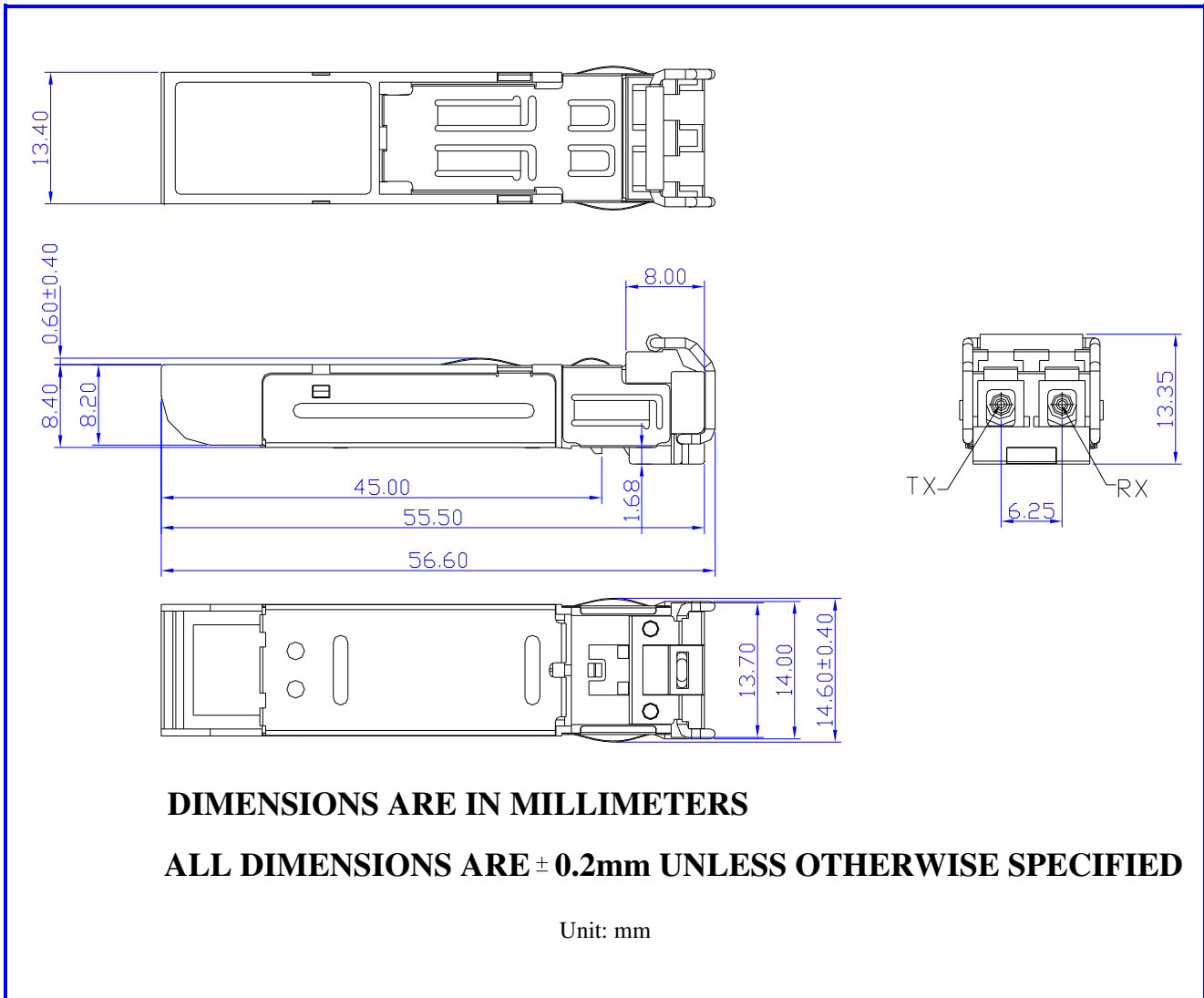

DIMENSIONS ARE IN MILLIMETERS

ALL DIMENSIONS ARE ± 0.2mm UNLESS OTHERWISE SPECIFIED

Unit: mm

RoHS Compliant
850 nm Multi-mode Transceiver
Small Form Pluggable (SFP), with Diagnostic Monitoring
Fiber Channel 10G,8.5G,4.25G, 2.125G, 1.0625Gb/s,
10G BASE-SW/SR,1000 Base-SX Ethernet

SFP host board mechanical layout

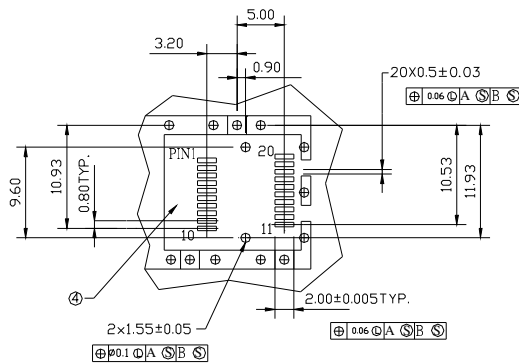
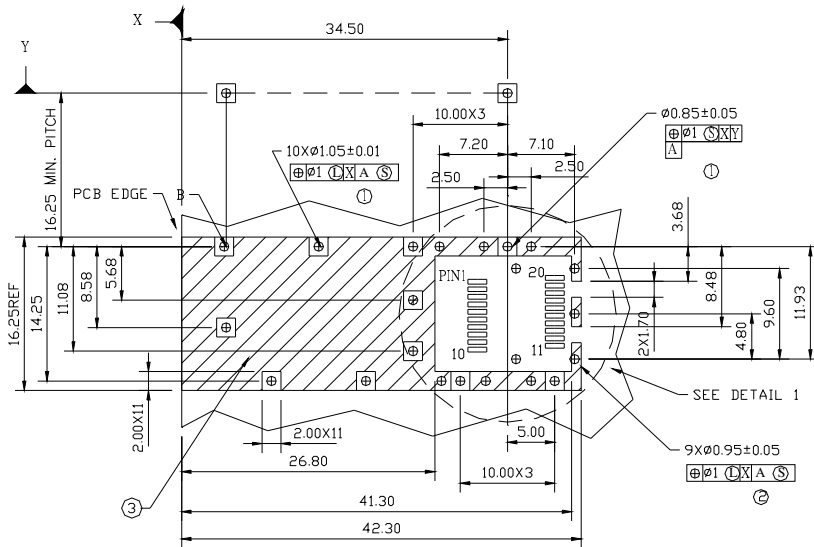

DETAIL 1

LEGEND

- 1.PADS AND VIAS ARE CHASSIS GROUND
- 2.THROUGH HOLES, PLATING OPTIONAL
- 3.HATCHED AREA DENOTES COMPONENT AND TRACE KEEPOUT(EXCEPT CHASSIS GROUND)
- 4.AREA DENOTES COMPONENT KEEPOUT (TRACES ALLOWED)

DIMENSIONS ARE IN MILLIMETERS

Unit: mm

RoHS Compliant
850 nm Multi-mode Transceiver
Small Form Pluggable (SFP), with Diagnostic Monitoring
Fiber Channel 10G,8.5G,4.25G, 2.125G, 1.0625Gb/s,
10G BASE-SW/SR,1000 Base-SX Ethernet

Assembly drawing

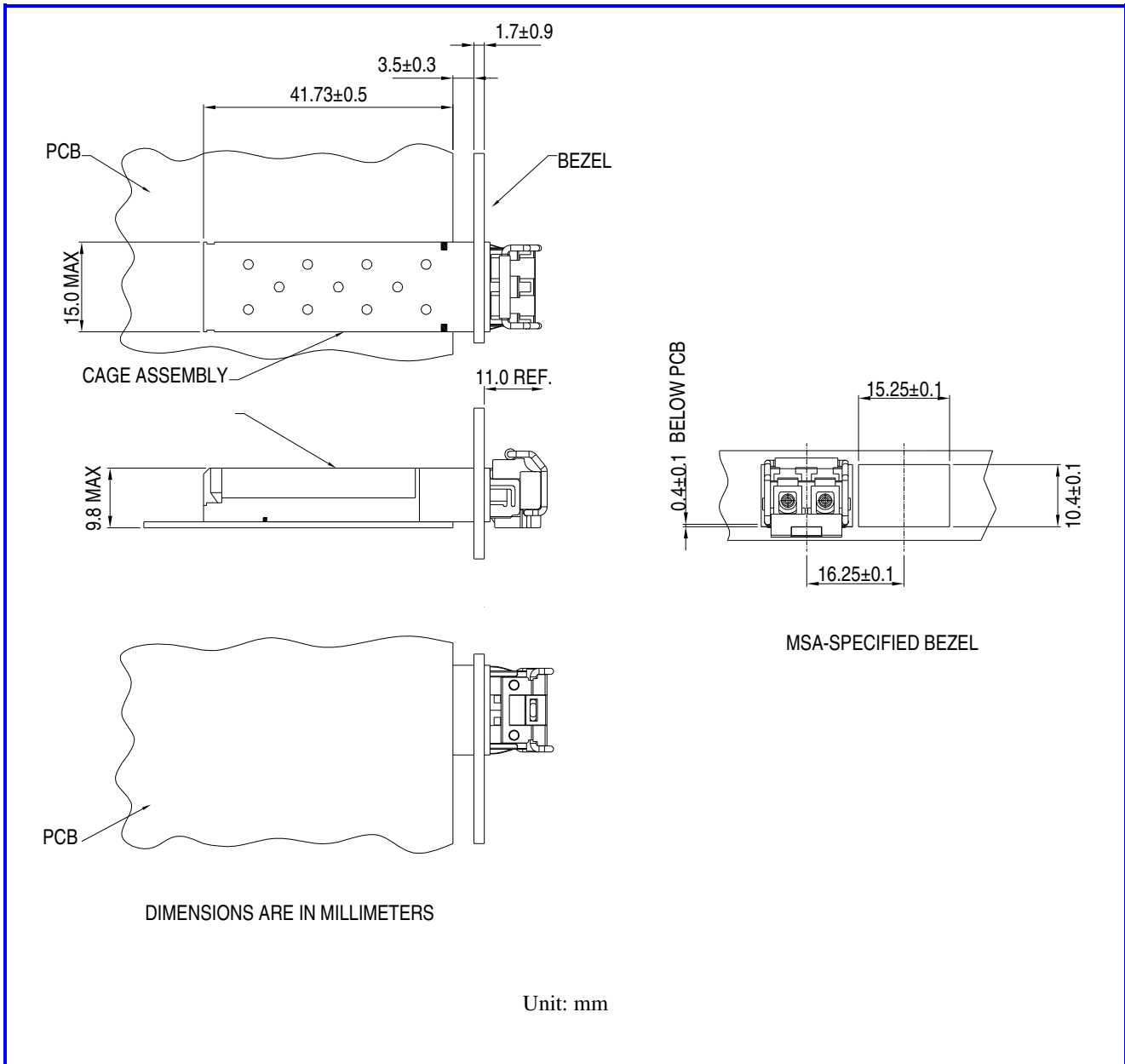

RoHS Compliant
850 nm Multi-mode Transceiver
Small Form Pluggable (SFP), with Diagnostic Monitoring
Fiber Channel 10G,8.5G,4.25G, 2.125G, 1.0625Gb/s,
10G BASE-SW/SR,1000 Base-SX Ethernet

Pin Assignment

Pin-Out

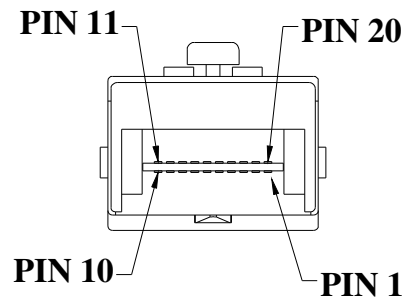

Pin	Signal Name	Description
1	T_{GND}	Transmit Ground
2	TX_FAULT	Transmit Fault
3	$TX_DISABLE$	Transmit Disable
4	$MOD_DEF (2)$	SDA Serial Data Signal
5	$MOD_DEF (1)$	SCL Serial Clock Signal
6	$MOD_DEF (0)$	TTL Low
7	$RS0$	RX Rate Select
8	RX_LOS	Receiver Loss of Signal, TTL High, open collector
9	$RS1$	TX Rate Select
10	R_{GND}	Receiver Ground
11	R_{GND}	Receiver Ground
12	$RX-$	Receive Data out Bar, ac coupled
13	$RX+$	Receive Data out, ac coupled
14	R_{GND}	Receiver Ground
15	V_{CCR}	Receiver Power Supply
16	V_{CCT}	Transmitter Power Supply
17	T_{GND}	Transmitter Ground
18	$TX+$	Transmit Data in, ac coupled
19	$TX-$	Transmit Data in Bar, ac coupled
20	T_{GND}	Transmitter Ground

RoHS Compliant
850 nm Multi-mode Transceiver
Small Form Pluggable (SFP), with Diagnostic Monitoring
Fiber Channel 10G,8.5G,4.25G, 2.125G, 1.0625Gb/s,
10G BASE-SW/SR,1000 Base-SX Ethernet

Eye Safety Mark

The AC35 series multimode transceiver is a class 1 laser product. It complies with EN 60825-1 and FDA 21 CFR 1040.10 and 1040.11. In order to meet laser safety requirements the transceiver shall be operated within the Absolute Maximum Ratings.

Caution

All adjustments have been done at the factory before the shipment of the devices. No maintenance and user serviceable part is required. Tampering with and modifying the performance of the device will result in voided product warranty.

Required Mark

**Class 1 Laser Product
Complies with
21 CFR 1040.10 and 1040.11**

Note : All information contained in this document is subject to change without notice.