

EX-G059C

HD/SD-SDI over Singlemode LC-type Fiber
Optic Extender Immune to Pathological

User Manual





Safety and Notice

The **EX-G059C HD/SD-SDI over Singlemode LC-type Fiber Optic Extender Immune to Pathological** has been tested for conformance to safety regulations and requirements, and has been certified for international use. However, like all electronic equipments, the **EX-G059C** should be used with care. Please read and follow the safety instructions to protect yourself from possible injury and to minimize the risk of damage to the unit.

- Follow all instructions and warnings marked on this unit.
- Do not attempt to service this unit yourself, except where explained in this manual.
- Provide proper ventilation and air circulation and do not use near water.
- Keep away the objects that might damage the device and assure that the placement of this unit is on a stable surface.
- Use only the power adapter, power cords and connection cables designed for this unit.
- Do not use liquid or aerosol cleaners to clean this unit. Always unplug the power to the device before cleaning.

Introduction

The EX-G059C is an ideal and economic solution designed for transmission of multi-rate SDI video, with embedded audio and metadata over a single-mode fiber optic cable. The transmitter module receives one HD/SDI electrical input, perfectly converts SMPTE 292M, SMPTE 259M or DVB-ASI electrical SDI signal to single-mode optical SDI signals. The receiver module receives optical signal from input LC connector, and then perfectly converts it to electrical SDI signal. EX-G059C is immune to pathological pattern (SMPTE RP-198) without introducing any flickers, and this feature further guarantees the transmission quality over optical fibers.

Both transmitter and receiver provide equalizing and reclocking at input unit in order to re-construct the signal for consistent quality. The EX-G059C is perfect for today's broadcast applications, including video production, video editing, studio to studio and studio to CATV head end. In addition, since transmission of content is inherently secure and immune to outside interference, fiber applications are favored in government, military, and medical environments.

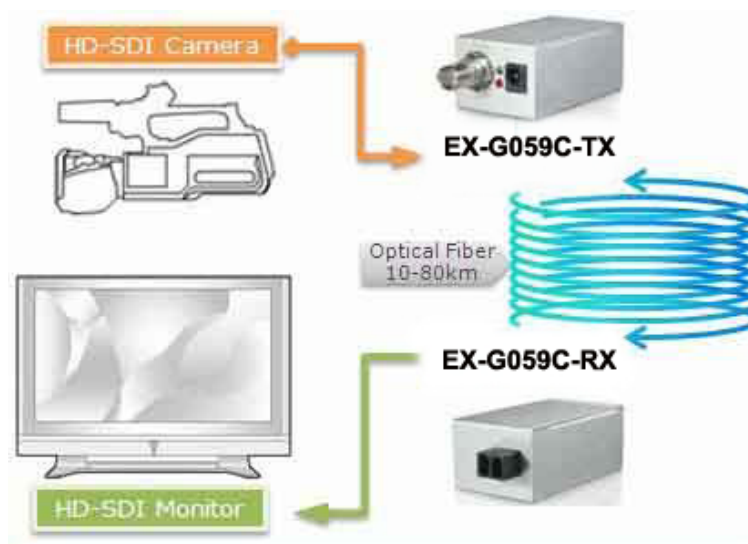

Performance Fact		
	SD-SDI	HD-SDI
EX-G059C10	>10 km/6.25 mi	10 km/6.25 mi
EX-G059C20	>20 km/12.5 mi	20 km/12.5 mi
EX-G059C80	>80 km/50 mi	80 km/50 mi

Features

- Enable transmission of digital video signal over optical fiber*
 - up to 10 km (6.25 miles) [EX-G059C10]
 - up to 20 km (12.5 miles) [EX-G059C20]
 - up to 80 km (50 miles) [EX-G059C80]
- Automatic cable EQ up to 300m (1000ft) at SD-SDI or 150m (500ft) for HD-SDI
- Standard LC-type fiber optic connector
- Supports following protocols:
 - SMPTE 259M (270Mbps)
 - SMPTE 259M (360Mbps)
 - SMPTE 292M / HDTV (1.485Gbps and 1.485/1.001Gbps)
 - DVB ASI (270Mbps)
- Immune to RP-918 pathological patterns
- Automatic reclocked / Manual bypass (optional upon request)
- One SDI loop out (optional upon request)
- HD/SDI Input signal detection LED



Depend upon models

SDI over Fiber Series Lineup

	EX-G059A	EX-G059D	EX-G059C	EX-G059B	EX-G060A	EX-G060C	EX-G060C
SDI Loop-Out				●	●	●	●
Fiber Loop-Out						●	●
DVB Support	●	●	●	●	●	●	●
Immune to RP-198 ¹			●	●	●	●	●
HD/SD Detection	●	●	●	●	●	●	●
Re-clocking	●	●	●	●	●	●	●
Cable EQ	●	●	●	●	●	●	●
Jitter (<0.2 UI)	●	●	●	●	●	●	●
Bandwidth(1.5Gbps)	●	●	●	●	●	●	●
Fiber Type ²	M	S	S	M	S	S	S
Optics type	LC	LC	LC	LC	LC	LC	SFP
Transmission ³	~500m	~80km	~80km	~500m	~80km	~80km	~10km



¹ RP-198 is the Pathological Patterns.

² Fiber type: M = multi-mode; S = single-mode.

³ Maximum transmission length is depended upon the optics module.

Specifications & Package Contents

Model Name		EX-G059C	
Technical		EX-G059C-TX	EX-G059C-RX
Role of usage		Transmitter [TX]	Receiver [RX]
SDI standards		SD-SDI & HD-SDI	
Auto HD/SD-SDI detection		Yes	
Supported protocols		SMPTE 259M (270Mbps / 360Mbps), DVB ASI (270Mbps) SMPTE 292M / HDTV (1.485Gbps and 1.485/1.001Gbps)	
Video bandwidth		[1.485Gpbs & 1.485/1.001Gbps]	
Data rates		270 / 1483 / 1485 Mbps	
Video support		[HD] 720p50/59.94/60, 1035i50/59.94/60, 1080i50/59.94/60, 1080p24/30 [SD] NTSC@59.94Hz, PAL@50Hz	
SDI signal type		SMPTE-292M, SMPTE-259M, DVB-ASI	
Output impedance		75Ω	
Auto reclocker mode		Automatic detection: 270Mbps / 1.483Gbps / 1.485Gbps Automatic bypass: 177Mbps / 360Mbps / 540Mbps	
Fiber Transmission		10km (6.25mi) [EX-G059C10] / 20km (12.5mi) [EX-G059C20] / 80km (50mi) [EX-G059C80]	
Cable (Belden 1294A) equalization / transmission		[HD-SDI] up to 150m (500ft) [SD-SDI] up to 300m (1000ft)	[HD-SDI] greater than 125m (410ft) [SD-SDI] up to 300m (1000ft)
Loop-out		1 reclocking SDI loop-out [optional upon request]	
Audio support		Yes	
RP-918 pathological patterns		Immune	
PCB Stack-up		4-layer board [impedance control — differential 100Ω; single 50Ω]	
Input		1x BNC [SDI]	1x Optical LC [SDI]
Output		1x Optical LC [SDI] 1x BNC [SDI] (optional loop-out)	1x BNC [SDI] 1x BNC [SDI] (optional upon request)
BNC connector		75Ω inter-locked socket	
Optical fiber connector		LC-type	
Fiber optics		Wavelength: 1310 nm [EX-G059C10] 1550nm [EX-G059C20 / EX-G059C80] Type: Single-mode Jitter < 0.2 UI Overshoot < 10% Optical power: [EX-G059C10]-3~-9 dBm [EX-G059C80] -1~4 dBm	
		Extinction ratio: typical 9.5 (minimum 5) Rise/fall: 135~800 pS Receiver sensitivity: -18 dBm	
Mechanical			
Housing		Metal case	
Dimensions [L x W x H]	Model	110 x 40 x 30mm [4.3"x1.6"x1.2"]	
	Package	330 x 200 x 95mm [1'1"x7.9"x3.7"]	
	Carton	495 x 440 x 380mm [1'7.5"x1'5.3"x1'3"]	
Weight	Model	[TX / RX] – 135g [4.8oz]	
	Package	1075g [2.4 lbs]	
Fixedness		Inter-locked power supply	
Power supply		5V 4A DC	
Power consumption		10 Watts [max]	
Operation temperature		0~40°C [32~104°F]	
Storage temperature		-20~60°C [-4~140°F]	
Relative humidity		20~90% RH [no condensation]	
Package Contents		1x EX-G059C [TX & RX]	2x 5V power adapter 1x User Manual

Panel Descriptions

Transmitter (EX-G059C-TX)

Front Panel

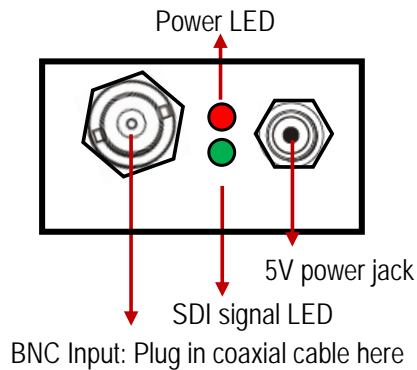

Rear Panel

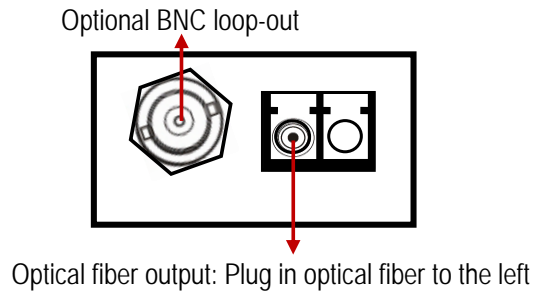

Receiver (EX-G059C-RX)

Front Panel

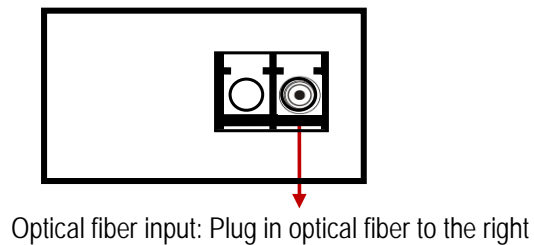

Rear Panel

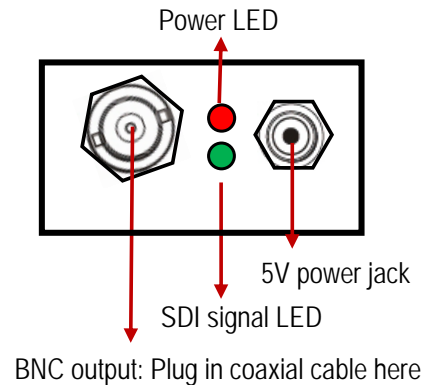

Limited Warranty

The SELLER warrants the **EX-G059C HD/SD-SDI over Singlemode LC-type Fiber Optic Extender Immune to Pathological** to be free from defects in the material and workmanship for 1 year from the date of purchase from the SELLER or an authorized dealer. Should this product fail to be in good working order within 1 year warranty period, The SELLER, at its option, repair or replace the unit, provided that the unit has not been subjected to accident, disaster, abuse or any unauthorized modifications including static discharge and power surges.

Unit that fails under conditions other than those covered will be repaired at the current price of parts and labor in effect at the time of repair. Such repairs are warranted for 90 days from the day of reshipment to the BUYER. If the unit is delivered by mail, customers agree to insure the unit or assume the risk of loss or damage in transit. Under no circumstances will a unit be accepted without a return authorization number.

The warranty is in lieu of all other warranties expressed or implied, including without limitations, any other implied warranty or fitness or merchantability for any particular purpose, all of which are expressly disclaimed.

Proof of sale may be required in order to claim warranty. Customers outside Taiwan are responsible for shipping charges to and from the SELLER. Cables are limited to a 30 day warranty and cable must be free from any markings, scratches, and neatly coiled.

The content of this manual has been carefully checked and is believed to be accurate. However, The SELLER assumes no responsibility for any inaccuracies that may be contained in this manual. The SELLER will NOT be liable for direct, indirect, incidental, special, or consequential damages resulting from any defect or omission in this manual, even if advised of the possibility of such damages. Also, the technical information contained herein regarding the EX-G059C features and specifications is subject to change without further notice.