

DVI over Single CAT5 Series

EX-G025

DVI to HDMI over Single CAT5 Mini-Extender

User Manual





Safety and Notice

The **EX-G025 DVI to HDMI over Single CAT5 Mini-Extender** has been tested for conformance to safety regulations and requirements, and has been certified for international use. However, like all electronic equipments, the EX-G025 should be used with care. Please read and follow the safety instructions to protect yourself from possible injury and to minimize the risk of damage to the unit.

- Follow all instructions and warnings marked on this unit.
- Do not attempt to service this unit yourself, except where explained in this manual.
- Provide proper ventilation and air circulation and do not use near water.
- Keep objects that might damage the device and assure that the placement of this unit is on a stable surface.
- Use only the power adapter and power cords and connection cables designed for this unit.
- Do not use liquid or aerosol cleaners to clean this unit. Always unplug the power to the device before cleaning.



Introduction

The **EX-G025 DVI to HDMI over Single CAT5 Mini-Extender** extends the DVI to HDMI transmission distance up to 40m (130ft) under HD resolution 720p or 1080i. With EX-G025, users can transmit high quality digital video of PC applications through one cost effective CAT-5/5e to the remote HDMI display or projector, instead of using short and expensive DVI-HDMI cables. With embedded EDID inside the extender, your PC will continue to send the digital video even when the HDMI display is not connected.

The EX-G025 includes a transmitting unit (EX-G025-TX) and a receiving unit (EX-G025-RX). The transmitting unit is connected to your PC DVI output and the receiving unit is connected to the HDMI display or projector. While successfully connected, the two LED lights on each RJ-45 connector will blink. The transmission distance between the transmitting and receiving units can be up to 40m (130ft) under HD (720p/1080i) or 25m (80ft) under Full HD (1080p). With compact size and requiring no power, EX-G025 is the most cost effective choice for bringing your impressive digital video to the remote HDTV.

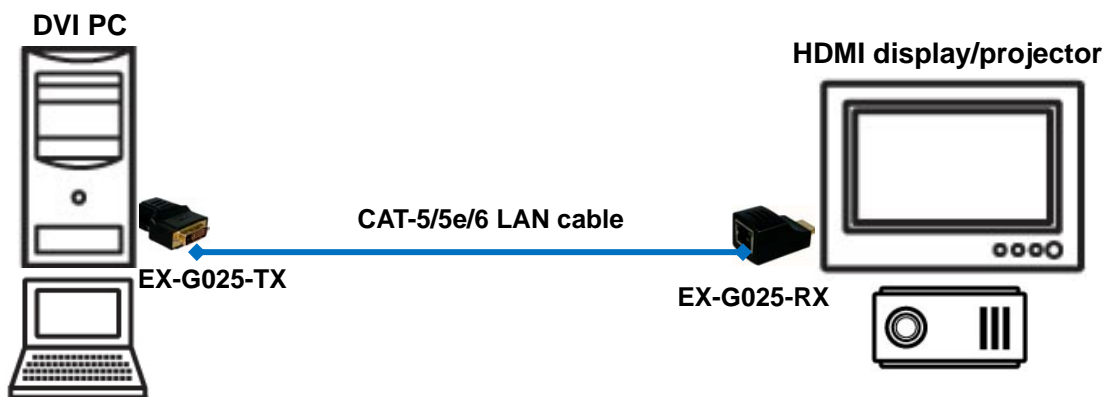

Features

- DVI 1.1 & HDMI 1.2a compliant
- Handy DVI-D to RJ-45 and HDMI to RJ-45 adapters with programmable EDID feature
- Extend the transmission length up to 40m (130ft) under HD (720p or 1080i) or 25m (80ft) under Full HD (1080p)
- No power required
- Compact size, direct plug-in
- Pure unaltered uncompressed 7.1ch digital HDMI over LAN cable transmission
- Perfectly integrated with other HDMI over CAT5 series products



The length depends on the characteristics and quality of the cables. Higher resolutions and longer transmission distances require low skew cables (<25ns/100m) for best performance. Unshielded CAT6 with metal RJ-45 connectors is recommended.

Specifications & Package Contents

Model Name		EX-G025	
Technical		EX-G025-TX aka EX-G026A	EX-G025-RX aka EX-G076B
Role of usage		Transmitter [TX]	Receiver [RX]
HDMI compliance		HDMI 1.2a	
DVI compliance		DVI 1.1	
Video bandwidth		Single-link 165MHz [4.95Gbps]	
Video support		Up to 1080p60, WUXGA [1920x1200@60] & UXGA [1600x1200@60]	
Transmission over LAN		Full HD (1080p) – 25m [80ft] for CAT5e / 30m [100ft] for CAT6 HD (720p/1080i) – 40m [130ft] for CAT5e / 45m [150ft] for CAT6	
Audio support		No audio for DVI signal	
Equalization		None	
Input TMDS signal		1.2 Volts [peak-to-peak]	
Input DDC signal		5 Volts [peak-to-peak, TTL]	
PCB stack-up		4-layer board [impedance control — differential 100Ω; single 50Ω]	
Input		1x DVI	1x RJ-45
Output		1x RJ-45	1x HDMI
HDMI connector		Type A [19-pin female]	
DVI connector		DVI-I [29-pin male, digital only]	
RJ-45 connector		WE/SS 8P8C with 2 LED indicators	
Mechanical		EX-G025-TX aka EX-G026A	EX-G025-RX aka EX-G076B
Housing		Plastic mold	
Dimensions [L x W x H]	Model	50 x 40 x 22mm [2" x 1.6" x 0.9"]	45 x 25 x 22mm [1.8" x 1" x 0.9"]
	Package	170 x 115 x 40mm [6.7" x 4.5" x 1.6"]	
	Carton	450 x 370 x 300mm [1'5.7" x 1'2.6" x 11.8"]	
Weight	Model	46g [1.7oz]	22g [0.8oz]
	Package	136g [4.8oz]	
Fixedness		Direct plug-in	
Power supply		None	
Power consumption		0.5 Watt [max]	
Operation temperature		0~40°C [32~104°F]	
Storage temperature		-20~60°C [-4~140°F]	
Relative humidity		20~90% RH [no condensation]	
Package Contents		1x EX-G025 [TX/RX] 1x User Manual	

Hardware Installation

1. Connect your transmitting unit EX-G025-TX to your DVI PC source.
2. Connect your receiving unit EX-G025-RX to your remote HDMI display or projector.
3. Make sure your CAT-5/5e/6 LAN cable is tightly connected and not loose.
4. Enjoy your high quality PC video on the screen.



Performance Fact		
	720p@1080i	1080p
HDMI over CAT5	40m/130ft	25m/80ft

DVI over Single CAT5 Series Lineup

	EX-G025	EX-G027	EX-G026A	EX-G020
Output to display	HDMI	DVI	DVI	DVI
Transmission over CAT5 at 1024x768@60Hz	25m [80ft]	60m [200ft]	25m [80ft]	30m [100ft]
Transmission over CAT5 at 1920x1200@60Hz	15m [50ft]	40m [130ft]	15m [50ft]	15m [50ft]
Power requirement	No	TX-No / RX-Yes	No	No
Equalization	No	Yes	No	No

Notice

1. If the DVI or HDMI device requires the EDID information, please use EDID Reader/Writer to retrieve and provide DVI/HDMI EDID information.
2. All HDMI over CAT5 transmission distances are measured using Belden 1583A CAT5e 125MHz LAN cable and ASTRODESIGN Video Signal Generator VG-859C.
3. The transmission length is largely affected by the type of LAN cables, the type of HDMI sources, and the type of HDMI display. The testing result shows solid LAN cables (usually in bulk cable 300m/1000ft form) can transmit a lot longer signals than stranded LAN cables (usually in patch cord form). Shielded STP cables are better suit than unshielded UTP cables. A solid UTP CAT5e cable shows longer transmission length than stranded STP CAT6 cable. For long extension users, solid LAN cables are your only choice.
4. EIA/TIA-568-B termination (T568B) for LAN cables is recommended for better performance.
5. To reduce the interference among the unshielded twisted pairs of wires in LAN cable, you can use shielded LAN cables to improve EMI problems, which is worsen in long transmission.
6. Because the quality of the LAN cables has the major effects in how long transmission distance will be made and how good is the received display, the actual transmission length is subject to your LAN cables. For resolution greater than 1080i or 1280x1024, a CAT6 cable is recommended.
7. If your HDMI display has multiple HDMI inputs, it is found that the first HDMI input [HDMI input #1] generally can produce better transmission performance among all HDMI inputs.



Performance Guide for DVI over LAN Cable Transmission

Performance rating		Type of LAN cable		
Wiring	Shielding	CAT5	CAT5e	CAT6
Solid	Unshielded (UTP)	★★★	★★★★	★★★★★
	Shielded (STP)	★★★	★★★	★★★★★
Stranded	Unshielded (UTP)	★	★★	★★
	Shielded (STP)	★	★	★★
Termination		Please use EIA/TIA-568-B termination (T568B) at any time		

Limited Warranty

The SELLER warrants the **EX-G025 DVI to HDMI over Single CAT5 Mini-Extender** to be free from defects in the material and workmanship for 1 year from the date of purchase from the SELLER or an authorized dealer. Should this product fail to be in good working order within 1 year warranty period, The SELLER, at its option, repair or replace the unit, provided that the unit has not been subjected to accident, disaster, abuse or any unauthorized modifications including static discharge and power surges.

Unit that fails under conditions other than those covered will be repaired at the current price of parts and labor in effect at the time of repair. Such repairs are warranted for 90 days from the day of reshipment to the BUYER. If the unit is delivered by mail, customers agree to insure the unit or assume the risk of loss or damage in transit. Under no circumstances will a unit be accepted without a return authorization number.

The warranty is in lieu of all other warranties expressed or implied, including without limitations, any other implied warranty or fitness or merchantability for any particular purpose, all of which are expressly disclaimed.

Proof of sale may be required in order to claim warranty. Customers outside Taiwan are responsible for shipping charges to and from the SELLER. Cables are limited to a 30 day warranty and cable must be free from any markings, scratches, and neatly coiled.

The content of this manual has been carefully checked and is believed to be accurate. However, The SELLER assumes no responsibility for any inaccuracies that may be contained in this manual. The SELLER will NOT be liable for direct, indirect, incidental, special, or consequential damages resulting from any defect or omission in this manual, even if advised of the possibility of such damages. Also, the technical information contained herein regarding the EX-G025 features and specifications is subject to change without further notice.

